

HV-10

10 000 lb Hydraulic Winch



PN 686546

Features Include

- Robust and reliable hydraulic winch for commercial and industrial applications.
- 5.9 in3 / rev highly efficient and constant operating torque motor with 10 000 lb capacity.
- Hardened 2-stage planetary gear train with 16:1 gear ratio provides rapid line speed.
- Manual or air free spool clutch options. Stainless Steel T-handle for rapid wire rope payout.
- Oil bathed Drag brake and load control valve provide controlled lowering and full load holding.
- Recommended for heavy duty trailers, roll-back carriers and commercial recovery application.
- Meets SAE J706 REVISED AUG2003, CE Machinery Directive 2006/42/EC and EN 14492-1 Power Driven Winches

Specifications

- Rated Line Pull: 4 535 kg / 10 000 lb SAE J706 Ratings
- Line Speed: 14 mpm 60 l / min at first layer of rope
- Operation Pressure: 150 bar/ 2 175 psi
- Max Oil Flow: 60 l / min
- Hydraulic Motor: 97 cm³ / rev
- Gear Train: 2-stage Planetary Gears
- Gear Ratio: 16:1
- Winch Construction: Aluminum die-cast housings with steel drum
- Clutch (Freespooling): Rotating ring gear
- Brake: Spring applied drag brake, load control valve
- Rotation of Winch: Rope under-wound orientation only
- Drum Barrel Diameter: 102 mm
- Drum Flange Diameter: 201.5 mm
- Distance Between Flanges: 253 mm
- Wire Rope Recommended: 11 mm x 27 m, 1,960 N/mm² (EIPS) grade.
A minimum breaking strength of 84.4 kN / 18 939 lbf required

Line Pull and Rope Capacity

Layer of Wire Rope	Pull by Layer kg / lb	Total Rope on Drum (m)	Line Speed at 60 l/min (mpm)
1 st	4 535 / 10 000	8.0	14.0
2 nd	3 796 / 8 369	17.5	16.3
3 rd	3 264 / 7 196	27.0	19.0

Dimensions mm/inch

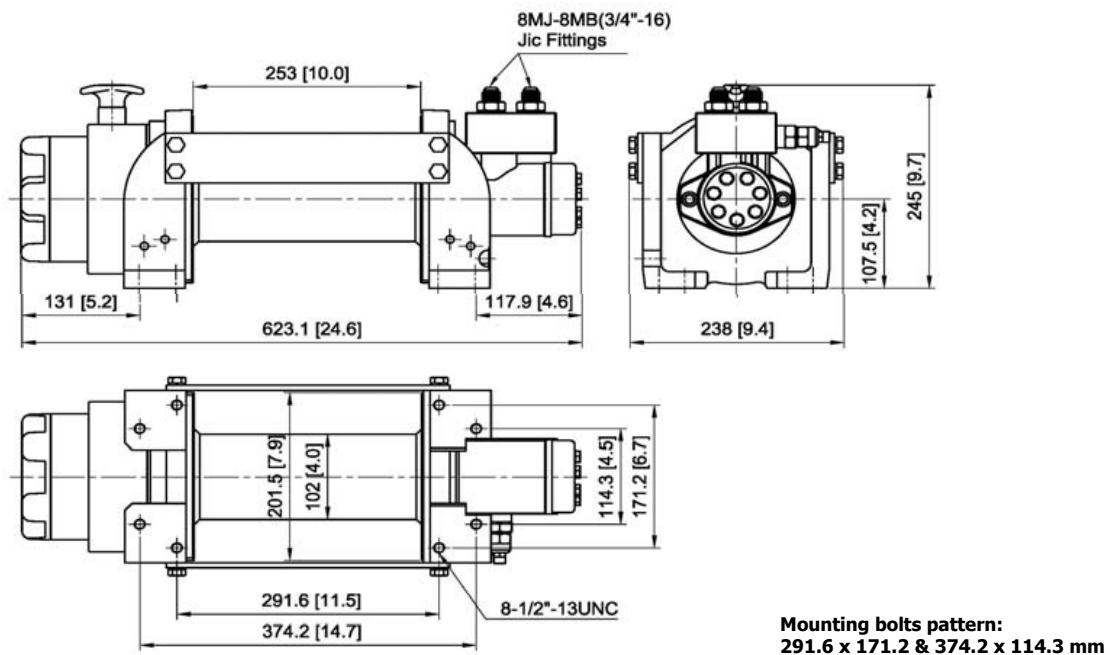

Packaging

Winch Weight: 37 kg
 Gross Weight: 46.6 kg
 Box Dimensions: 665 x 370 x 285 mm

Standard Accessories

Roller fairlead
 Load Control Valve

WARNING!

- Do not use winch to transport, lift or otherwise move personnel.
- The rated line pull shown is based on the first layer of wire rope on the drum.
- The wire rope must remain on the drum at all time with at least 5 wraps.

Warranty

Limited lifetime warranty for mechanical components and one year warranty for electrical components from date of purchase. Wire/Synthetic ropes are not included under warranty.